

| DATE | SYM | REVISION RECORD | ECN# | DR | CK |
|------|-----|-----------------|------|----|----|
|      |     |                 |      |    |    |
|      |     |                 |      |    |    |
|      |     |                 |      |    |    |
|      |     |                 |      |    |    |

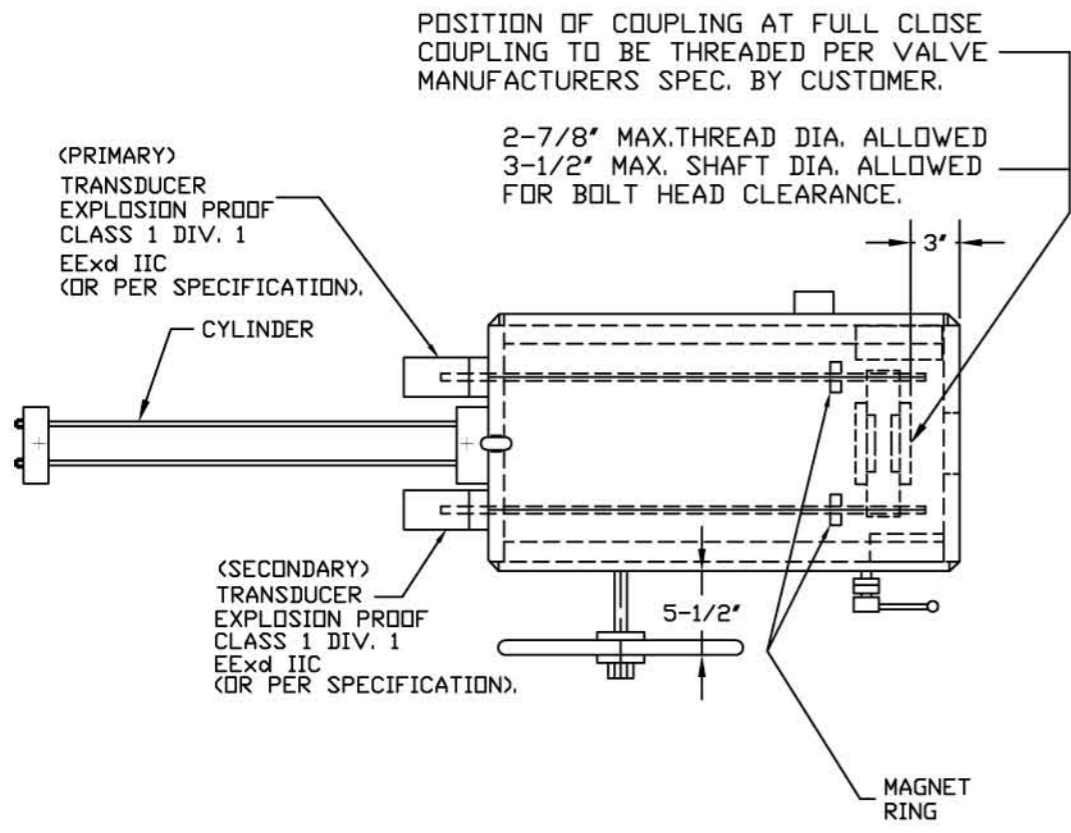

| MODEL NUMBER | CYLINDER    |         |           |          | POSITIONER DIM.D | WEIGHT LBS. |       |
|--------------|-------------|---------|-----------|----------|------------------|-------------|-------|
|              | BORE/STROKE | DIM.A   | PORT SIZE | DIM.B    |                  |             | DIM.C |
| 3-4K-12      | 3-1/4"/12"  | 20-3/4" | 1"        | 2-11/32" | 17"              | 31-1/8"     | 650   |
| 3-4K-18      | 3-1/4"/18"  | 26-3/4" |           | 2-11/32" | 23"              | 37-1/8"     | 695   |
| 3-4K-24      | 3-1/4"/24"  | 32-3/4" |           | 2-11/32" | 29"              | 43-1/8"     | 760   |
| 3-4K-30      | 3-1/4"/30"  | 38-3/4" |           | 2-11/32" | 35"              | 49-1/8"     | 815   |
| 3-4K-36      | 3-1/4"/36"  | 44-3/4" |           | 2-11/32" | 41"              | 55-1/8"     | 860   |
| 3-4K-42      | 3-1/4"/42"  | 50-3/4" |           | 2-11/32" | 47"              | 61-1/8"     | 895   |
| 3-6.4K-12    | 4"/12"      | 22-1/4" | 1-1/2"    | 2-3/8"   | 18"              | 31-1/8"     | 750   |
| 3-6.4K-18    | 4"/18"      | 28-1/4" |           | 2-3/8"   | 24"              | 37-1/8"     | 810   |
| 3-6.4K-24    | 4"/24"      | 34-1/4" |           | 2-3/8"   | 30"              | 43-1/8"     | 870   |
| 3-6.4K-30    | 4"/30"      | 40-1/4" |           | 2-3/8"   | 36"              | 49-1/8"     | 930   |
| 3-6.4K-36    | 4"/36"      | 46-1/4" |           | 2-3/8"   | 42"              | 55-1/8"     | 990   |
| 3-6.4K-42    | 4"/42"      | 52-1/4" |           | 2-3/8"   | 48"              | 61-1/8"     | 1050  |
| 3-10K-12     | 5"/12"      | 22-3/4" | 1-1/2"    | 2-7/8"   | 18"              | 31-1/8"     | 850   |
| 3-10K-18     | 5"/18"      | 28-3/4" |           | 2-7/8"   | 24"              | 37-1/8"     | 920   |
| 3-10K-24     | 5"/24"      | 34-3/4" |           | 2-7/8"   | 30"              | 43-1/8"     | 990   |
| 3-10K-30     | 5"/30"      | 40-3/4" |           | 2-7/8"   | 36"              | 49-1/8"     | 1060  |
| 3-10K-36     | 5"/36"      | 46-3/4" |           | 2-7/8"   | 42"              | 55-1/8"     | 1130  |
| 3-10K-42     | 5"/42"      | 52-3/4" |           | 2-7/8"   | 48"              | 61-1/8"     | 1200  |
| 3-15K-12     | 6"/12"      | 22-3/4" | 1-1/2"    | 2-7/8"   | 18"              | 31-1/8"     | 1000  |
| 3-15K-18     | 6"/18"      | 28-3/4" |           | 2-7/8"   | 24"              | 37-1/8"     | 1100  |
| 3-15K-24     | 6"/24"      | 34-3/4" |           | 2-7/8"   | 30"              | 43-1/8"     | 1200  |
| 3-15K-30     | 6"/30"      | 40-3/4" |           | 2-7/8"   | 36"              | 49-1/8"     | 1300  |
| 3-15K-36     | 6"/36"      | 46-3/4" |           | 2-7/8"   | 42"              | 55-1/8"     | 1400  |
| 3-15K-42     | 6"/42"      | 52-3/4" |           | 2-7/8"   | 48"              | 61-1/8"     | 1500  |

5 HP FOR DUAL UNITS (STD.)

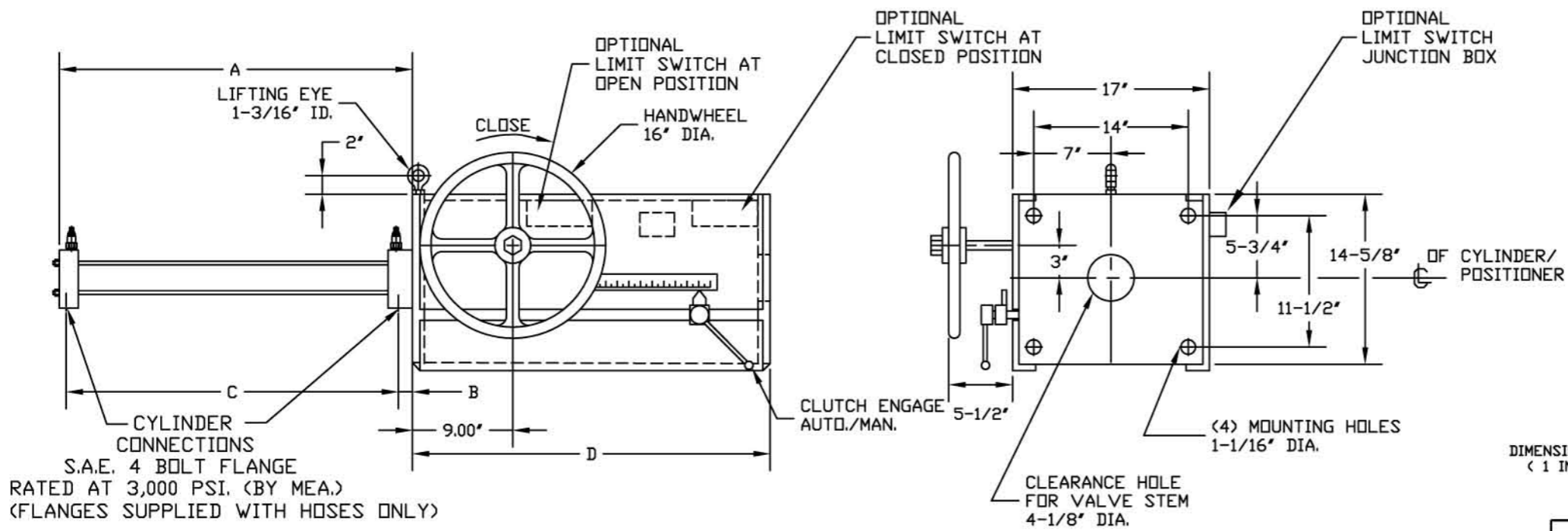

DIMENSIONS IN INCHES  
(1 INCH=25.4mm.)

NOTE:  
1. HANDWHEEL CAN BE ON EITHER SIDE.

THIS IS AN AUTOCAD DRAWING.  
DO NOT REVISE MANUALLY.

CAD FILE #  
11806

**MEI** INC., ELK GROVE, ILL.

THIS DRAWING IS THE PROPERTY OF MEI, INC. IT IS LOANED WITH THE UNDERSTANDING THAT IT MAY NOT BE REPRODUCED NOR MAY THE INFORMATION CONTAINED HEREIN BE USED FOR THE MAKING OF DRAWINGS OR FOR MANUFACTURING PURPOSES WITHOUT THE WRITTEN CONSENT OF MEI, INC.

|                                 |      |              |                |          |
|---------------------------------|------|--------------|----------------|----------|
| TOLERANCES<br>(EXCEPT AS NOTED) | ±N/A | SCALE<br>NTS | DRAWN BY<br>MC | CK<br>RM |
| APPROVED BY<br>MAC              |      |              |                |          |

TITLE  
ACTUATOR OUTLINE TEMPLATE

|                  |                             |           |
|------------------|-----------------------------|-----------|
| DATE<br>04-28-08 | DRAWING NUMBER<br>CP320-811 | REV.<br>0 |
|------------------|-----------------------------|-----------|